

1 2 3 4 5 6

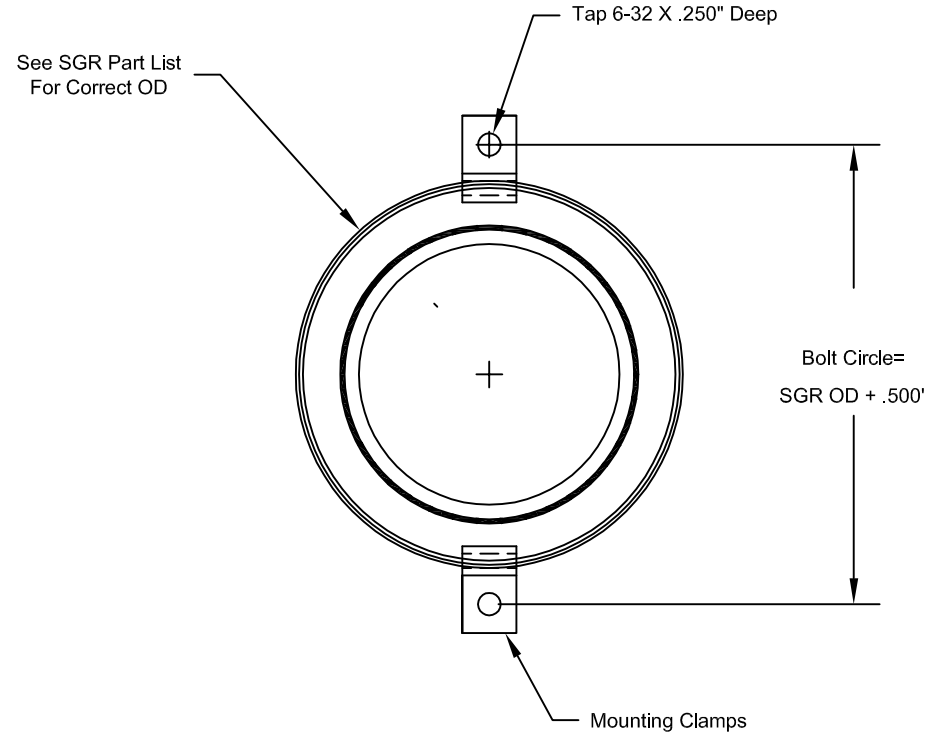
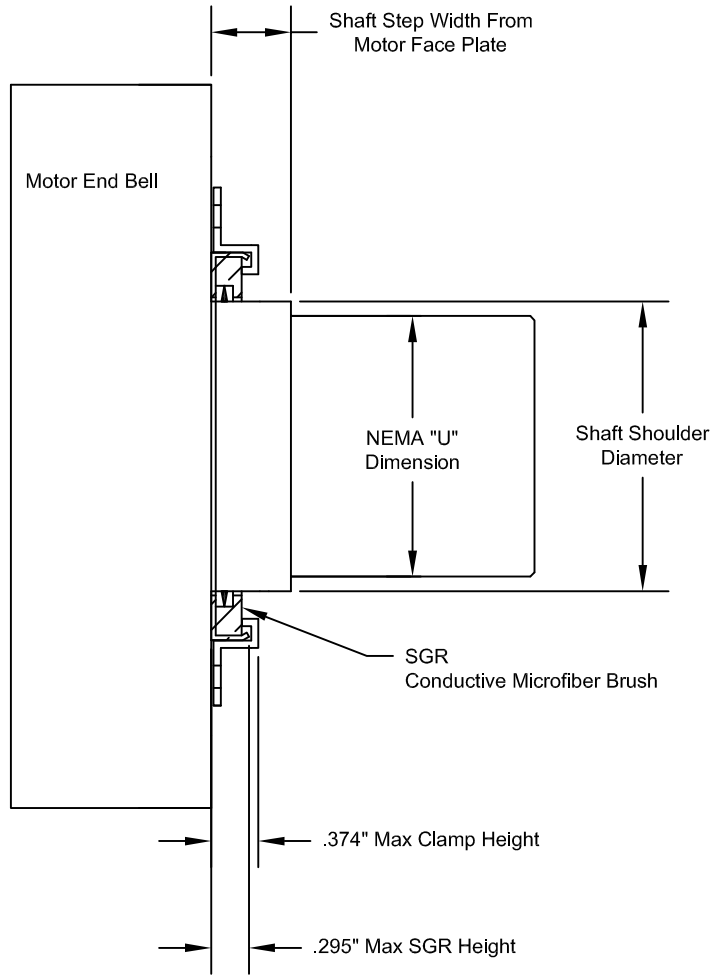

A  
B  
C  
D

A  
B  
C  
D

**SGR OD**

1.60"	4.60"
2.10"	5.10"
2.68"	5.60"
3.10"	6.10"
3.60"	6.60"
4.10"	7.10"

Note:  
To Be Supplied With Appropriate Number Of 6-32 X 1/4" SHCS  
And Internal Tooth Lock Washers.

THEREIN, ARE THE EXCLUSIVE PROPERTY OF ELECTRO STATIC TECHNOLOGY ISSUED IN STRICT CONFIDENCE AND SHALL NOT WITHOUT CONSENT, BE REPRODUCED, COPIED OR USED FOR ANY PURPOSE WHATSOEVER, EXCEPT BUSINESS WITH E.S.T.

UNLESS OTHERWISE SPECIFIED
DIMENSIONS ARE IN.
MILLIMETERS <input type="checkbox"/>
INCHES <input checked="" type="checkbox"/>
UNTOLERANCED DIMENSIONS
TOLERANCE
+/- .020"
DATE: 12/11/07
ENGINEER: J. Richardson



**ELECTRO STATIC TECHNOLOGY**  
AN ITW COMPANY

31 WINTERBROOK ROAD, MECHANIC FALLS, MAINE 04256  
PHONE (207)998-5140 FAX (207)998-5143

**AEGIS SGR Bearing Protection Ring**  
CUSTOMER:

EST P/N: SGR-XXX.X-1 Rev.

1 2 3 4 5 6